

SECTION 1: CHECK OPERATION

- a. To verify proper operation of the OM2000 System, connect the Motor Connector to the Electronics Module Connector so that the Red Wires are aligned. If Key Detection is installed connect the Key Detection Connector (Yellow wires) to the Electronics Module Connector (Yellow wires), there is no polarity.
- b. Verify proper keypad operation of the system by entering the Default Programmer ID **1 2 3 4** at the Keypad. The System will flash green once and unlock, then during the open delay it will flash green (5) times. It will then flash red and lock.
- c. Verify proper operation of the Magnetic Card Reader. A Label on the Battery Cover indicates the magnetic card track, Track 2 or Track 3, that the Lockset is set to read. Select the corresponding Default Programmer ID Card, insert and remove it with the magnetic stripe on the card aligned with the "V" mark by the card slot. The lights will flash as in the previous step.
- d. While unlocked, check for proper operation of the Lockset.
- e. If Key Detection is installed, verify proper operation of the Key Detection Indicator. (Otherwise, go to Step f.)
 1. Install the Key Cylinder into the Lock so that the cam on the end of the Cylinder is approximately centered in the Lock and the keyway is at the bottom.
 2. Remove the Faceplate and tighten the Cylinder Retaining Screw to keep the Cylinder from turning.
 3. Insert the Key into the Key Cylinder and rotate the Key to operate the Latch Bolt. The green light will flash.
- f. If the Lock malfunctions proceed as follows, otherwise go to Step g. Remove the Battery Cover and check for proper orientation and seating of the Batteries, the Motor Connector and the Key Detection Connector. Check that the Track Selection Jumper is in the desired position. Also ensure that the wires are not pinched. Reset the electronics by pressing and holding the Reset Button on the circuit board for approximately three (3) seconds, until the light flashes green. The Lockset will go through a self-test cycle and then flash green five (5) times. Replace the Battery Cover. Now repeat the verification process.
- g. After verifying proper operation, if your system requires use of the other magnetic track, proceed as follows, otherwise go to Step h:
 1. Remove the Battery Cover Retaining Screw and the Battery Cover.
 2. Move the Track Selection Jumper on the upper left corner of the circuit board to the desired track position.

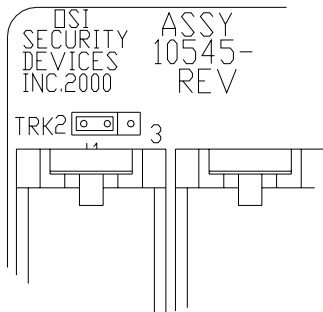

TRACK 2 SETTING

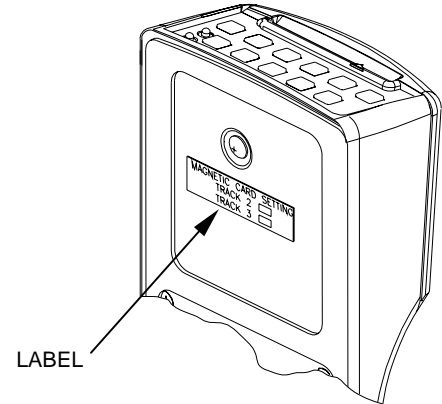
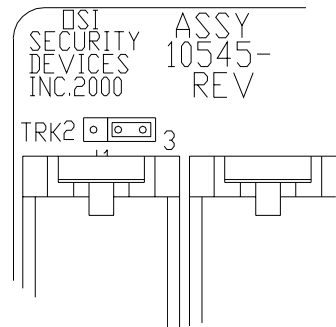

TRACK 3 SETTING

3. Mark the Label on the Battery Cover to indicate the selected track.
4. Replace the Battery Cover and secure with the Screw.
5. Insert and remove the corresponding Default Programmer ID Card. A light will flash green once and the lock will unlock, then, during the Open Delay Time it will flash five (5) times. A light will then flash red and the lock will lock.
- h. If the verification process was successful, disconnect the Motor Connector. If Key Detection is installed, disconnect the Key Detection Connector and remove the Key Cylinder from the Lock.

SECTION 2: ADJUST THE LOCK HAND

This section is only required if the lock hand, as received, does not meet your requirements. The Lock Chassis is normally preset for a Right Hand Door. Verify the hand of the Lock and, if required, change the hand of the Lock as follows after checking per Section 1.

- Pull the Anti-Friction Tongue and Latch bolt away from the Chassis and rotate the complete unit 180° to adjust for the Door Hand.
- Remove the Catch Screw from one side of the Chassis and install on the opposite side (Catch Screw must always be on the inside side of the Lock Chassis for proper functioning of the lock).

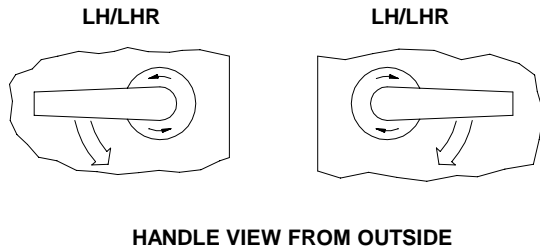

ANTI-FRICTION TONGUE AND LATCH BOLT
(Pull and rotate 180°)

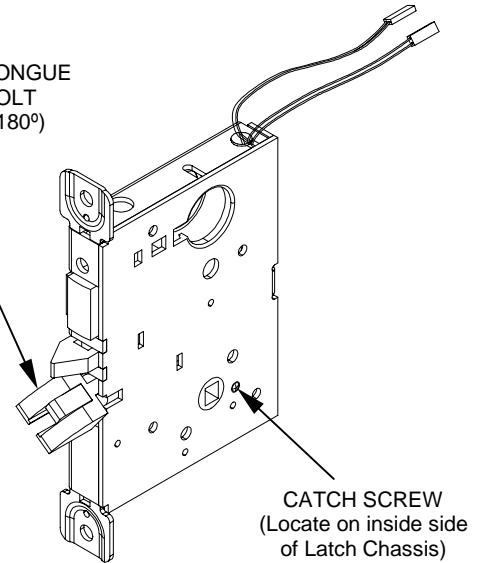

SECTION 3: PREPARE THE DOOR

3-1 MARK THE HEIGHT LINE

- Mark a Height line on the Door Faces and Edge (suggested height is 38" from the floor).

NOTE: If the Frame has already been prepared for a Schlage Strike, measure 2-3/32" down from the center of the Strike to locate the centerline of the Lever.

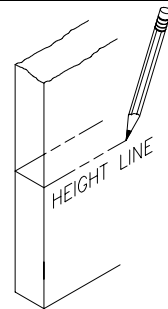

3-2 MARK THE DOOR SURFACE AND THE STRIKE POSITION

- Detach the Door Edge portion of the Template from the Door Surface portion of the Template.
- Line up the Door Surface portion of the Template at the correct marking for the Door Bevel (high or low bevel; or flat).
- Position the Lever Centerline of the Template on the Height line drawn on the Door.
- Spot only those holes required for the Lockset being installed.
- Mark the Centerline of the Strike position on the Frame.
- Spot both sides of the Door.

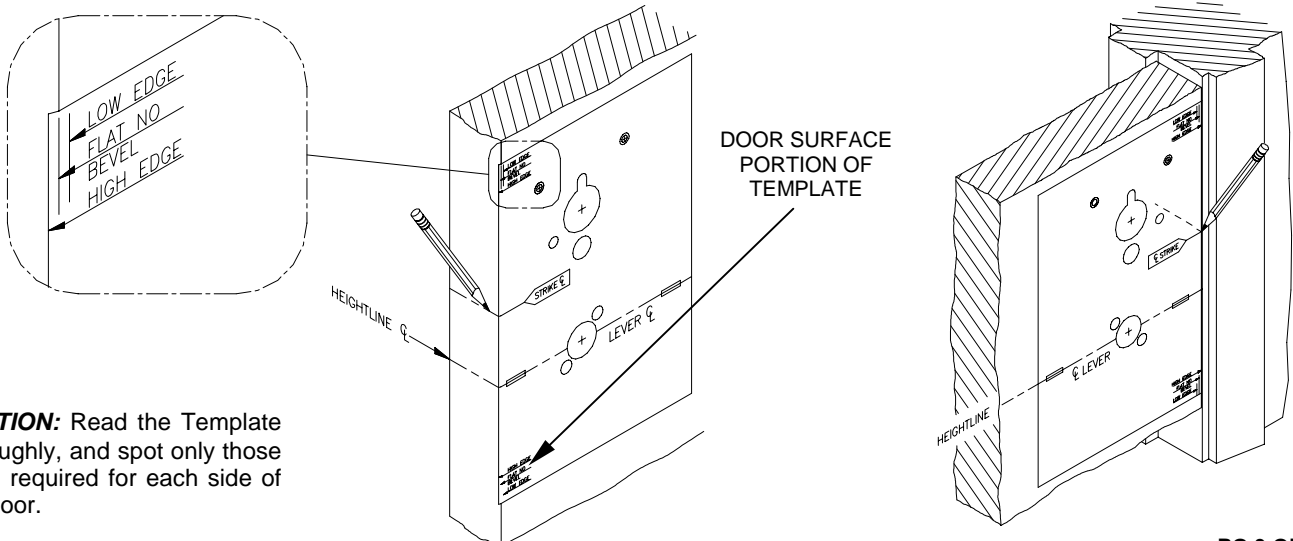

CAUTION: Read the Template thoroughly, and spot only those holes required for each side of the Door.

3-3 MARK THE DOOR EDGE

- Center the Door Edge portion of the Template on the Door Edge and align the Lever Centerline of the Template on the height line drawn on the Door.
- Spot the top and bottom points of the Lock Case Mortise and mark the Face Plate top reference as illustrated.

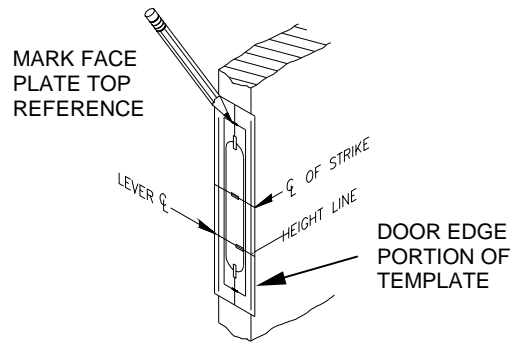

3-4 MORTISE THE DOOR EDGE

- Mortise the Door Edge for the Lock Case to the dimensions shown on the Template.
 - Insert the Lock (with the Face Plate attached) into the Mortise.
- CAUTION: Do not pinch the Wires.**
- Center the Face Plate (Lock attached) on the Door Edge and align the top of the Face Plate with the reference mark. Scribe the Face Plate outline as illustrated. Remove the Lock from the door.
 - Mortise the Door Edge to the Lock Face thickness.

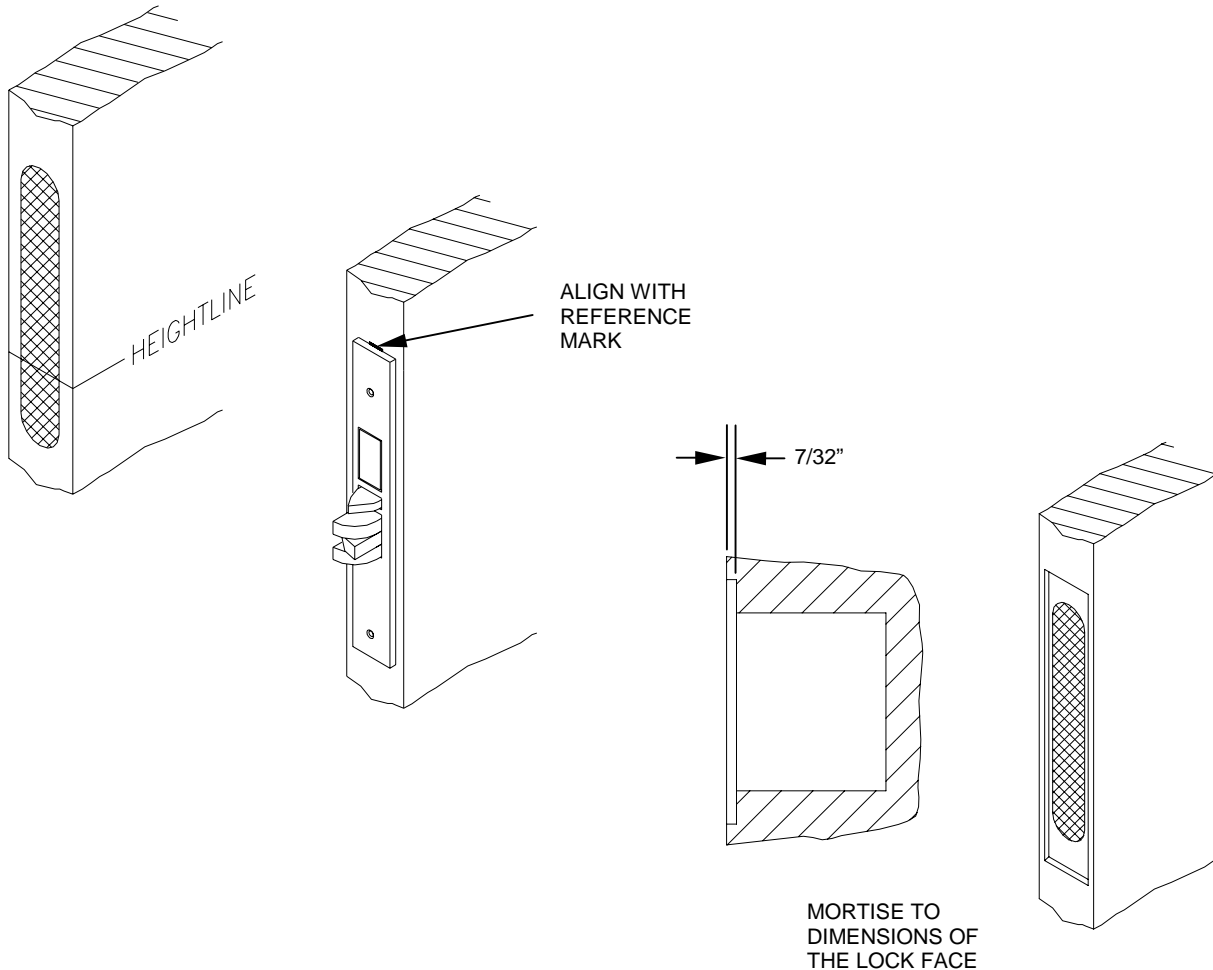

3-5 DRILL THE DOOR SURFACE HOLES

- Drill the required holes on the outside and inside of the Door.
- CAUTION: Drill the holes only halfway through the Door from each side.**

4-1

- a. Remove the Face Plate and guide the Connector(s) and the Lock into the Mortise so that the Wires pass through the slot above the Cylinder Hole and the lock is seated in the Mortise.

CAUTION: DO NOT PINCH THE WIRES

- b. Spot the hole location for the Case Attachment Screws and remove the Lock from the Mortise. For Wood Doors, drill 1/8" dia pilot holes for the Case Attachment Screws, and counter drill the holes 7/32" dia X 3/16" deep for Combination Screws. For Metal Doors, drill 3/16" dia holes.
- c. Install the Lock into the mortise and secure with the screws.

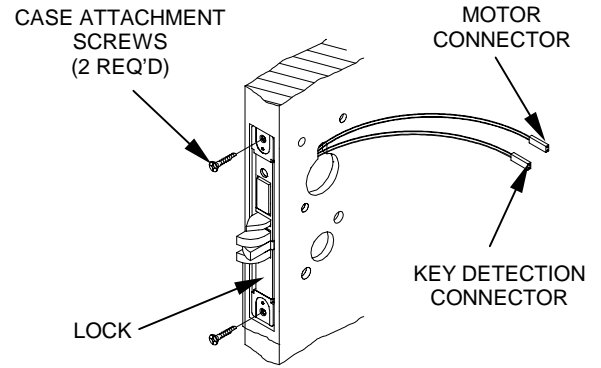

4-2 ATTACH THE TRIM

- a. Insert the Inside and Outside Spindles and Springs so that the Shoulder of the Spindle is in contact with the Hub of the Lock case.
- b. Thread the Screw Posts into the Outside Rose.
- c. Place the Spring Cage onto the Screw Posts with the arrows on the Spring Cage pointing in the direction of the Lever rotation.
- d. Install the Outside Trim onto the Outside Spindle with the Screw Posts through the holes in the Lock Case.
- e. Slide the Inside Spring Cage over the Inside Spindle and Screw Posts (Arrows on the Spring Cage pointing in the direction of the Lever rotation).
- f. Place the Mounting Plate over the Inside Spindle. Align the Screw Holes with the Screw Posts.
- g. Insert and tighten the Mounting Screws.

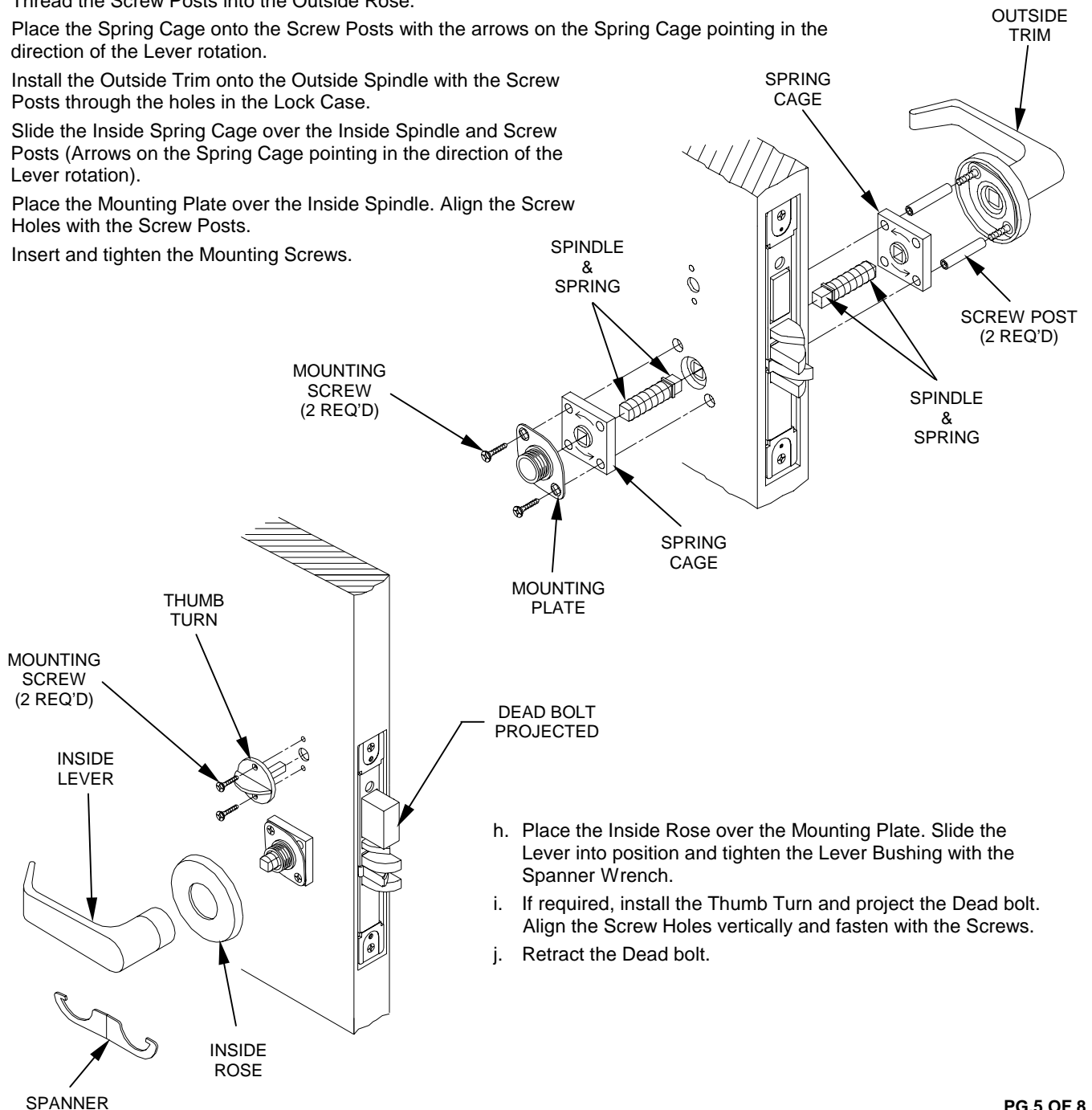

- h. Place the Inside Rose over the Mounting Plate. Slide the Lever into position and tighten the Lever Bushing with the Spanner Wrench.
- i. If required, install the Thumb Turn and project the Dead bolt. Align the Screw Holes vertically and fasten with the Screws.
- j. Retract the Dead bolt.

4-3 INSTALL THE ELECTRONICS MODULE

- Guide the Connector(s) through the front hole in the Module and place the Module against the Door so that the Standoffs and the Grounding Spring enter their respective holes.
- Install the Mounting Screws and Washers finger tight.
- Connect the Motor Connector (Red and Black Wires) to the Module Connector so that the Wire colors match. If installed, connect the Key Detection Connector to the Module Connector (Yellow Wires).
- Insert the Cables and the Connectors into the Module so that they are clear of the Cylinder Hole.

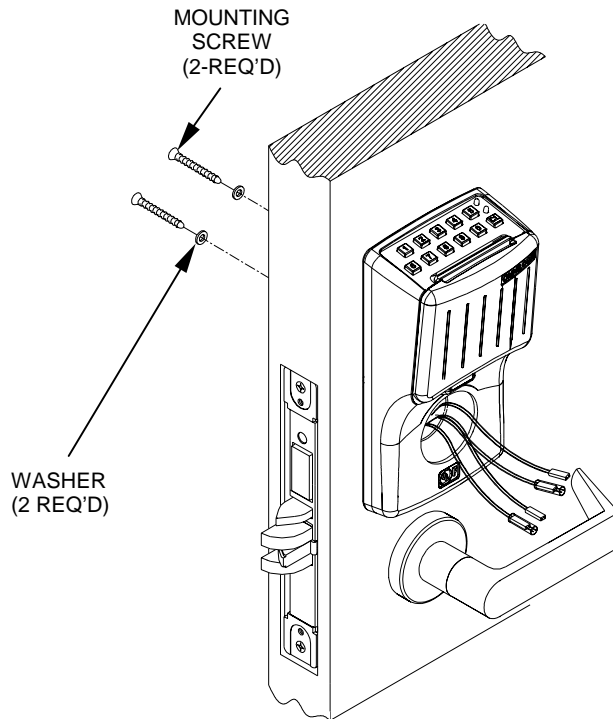

4-4 INSTALL THE CYLINDER

- Insert the Cylinder with the Wavy Washer and Collar into the Module and partially screw it into the lock.
- Ensure that the Module is Vertical and tighten the Module Mounting Screws. Then tighten the Cylinder until it is snug with the keyway at the bottom.
- Tighten the Cylinder Retaining Screw and install the Face Plate.
- Repeat steps 1b through 1d, and step 1e3 if Key Detection is installed, to verify operation.

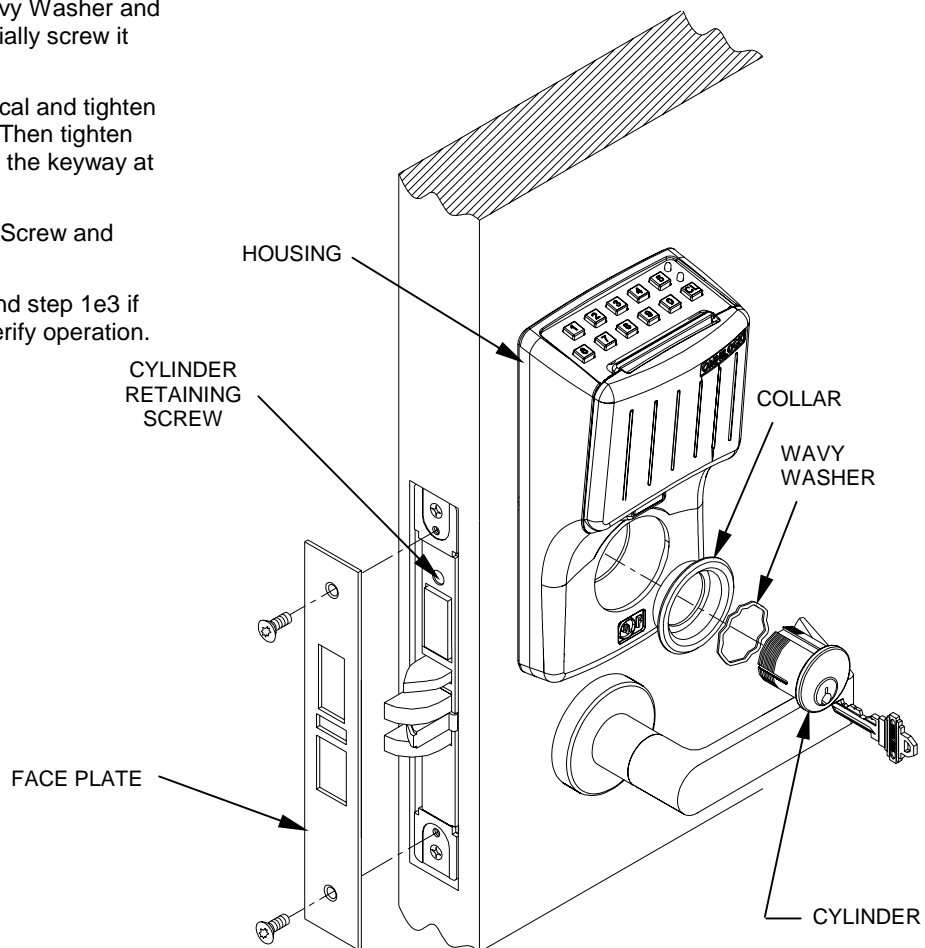

SECTION 5: INSTALL THE STRIKE

- a. Draw a vertical line on the Door Frame 1/2 the Door thickness from the Door Stop.

CAUTION: Allow for paint buildup or weather stripping if required.

- b. Align the Strike Template with the vertical line and the Strike centerline mark on the Door Frame from Section 3-2e. Spot the mortise and mounting holes and mark for the strike recess.
- c. Mortise the Door Frame for the Strike Box to the dimensions shown on the Template.

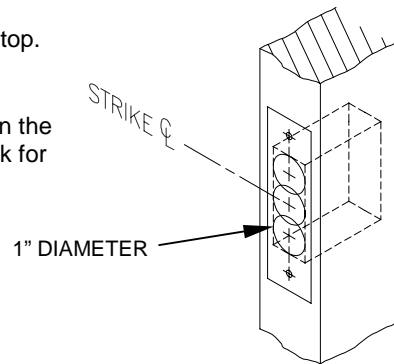
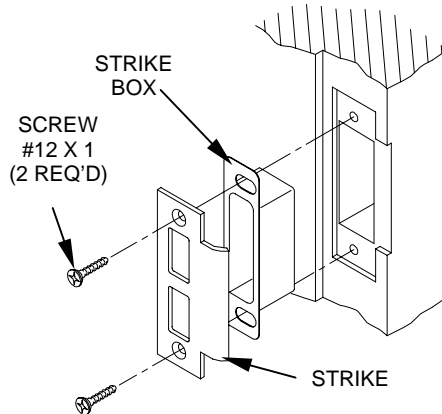

- d. Recess 5/32" for flush fit of the Strike and the Strike Box. (Additional recess is required when using strike reinforcement.)
- e. Drill the required mounting holes.

NOTE: For wood doors, drill 1/8" dia pilot holes and counter drill the holes 7/32" dia X 3/16" deep for Combination Screws. For metal doors, drill 3/16" dia holes.

- f. Install the Strike Box and the Strike and secure with the Screws.

CAUTION: Be sure the Auxiliary Latch does not enter the Strike opening

SECTION 6: PROGRAMMING THE SYSTEM

IMPORTANT: To avoid unauthorized access, it is important to program a new Programmer ID.

Refer to the OMNILOCK OM2000 Administrator's Guide for programming instructions. If the Lockset has been installed on a door before the required programming information is available, the Access Level may be set to unlocked as follows:

1. Enter the Default Manager ID **2 2 2 2** at the Keypad, the green light will flash.
2. Press **2**, the green light will flash.
3. Press and hold the **CL** key until the green light flashes four times. (The light will flash once when the CL key is first pressed, continue to hold the key until the light flashes (3) more times.)
4. The Lock will remain in the Unlocked mode.

SECTION 7: REMOTE SWITCH

- a. Remote operation of the System may be accomplished by a momentary Switch closure. This may be desirable for someone monitoring a protected entrance, such as a receptionist. Momentarily pressing the Switch will cause the System to go through a normal unlock and lock sequence. If the Switch is held closed, the open time will be extended.
- b. Connect a **twisted pair** of wires from the Terminal Block on the PC Board to a normally open momentary contact Switch. Plan the route for your wire and the access route through the door to the PC Board in the OMNILOCK Module. Plan for disconnecting the wires in the Module area so that the System can be removed from the door to change the Batteries as required.

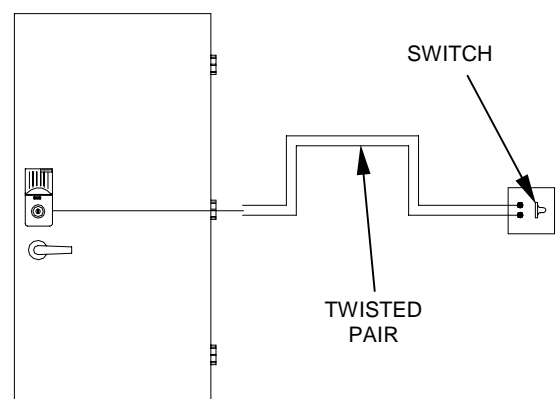

NOTES: